

Service Bulletin

S.B. No: 169

Title: **INSPECTION OF ENGINE INTAKE DUCT MESH AND ALTERNATE AIR DOOR**

Classification: This Service Bulletin has been classified by SAL as Essential

Compliance: At next 50 flying hour check

Applicability: T67M, T67M-MkII

INTRODUCTION:

Cases have been reported of both the engine air intake duct mesh cracking and of alternate air door rivets loosening. These cases have been reported only where T67M-50-101 intake ducts have been fitted: however this Service Bulletin also relates to T67M-50-103 intake ducts.

This Service Bulletin requires an inspection and, if applicable, repair.

ACTION:

1. Check master switch, ignition switch and fuel are OFF. Disconnect external power and hangar aircraft, if required.
2. Remove engine cowls.
3. Remove air intake filter retainer and filter element.
4. Inspect mesh within intake duct for cracking and loose retaining rivets.
5. Inspect riveted joint between alternate air door and intake duct for condition and any signs of movement. Movement of alternate air door should be smooth throughout its normal travel
6. Place straight edge across top of air duct adjacent to the alternate air door retaining rivets and check for distortion, ref. Figure 2. Any distortion of this face will effect the alternate air door operation.
7. Should inspections at paragraphs. 4, 5 and 6 be considered to be unsatisfactory, then return intake duct assembly to SAL.

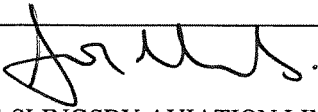
Approved by:  For and on behalf of SLINGSBY AVIATION LIMITED	Date: 27.7.00.	Issue 1
Kirkbymoorside, York. YO62 6EZ Tel: 01751 432474 Fax No: 01751 431173 E-mail: SAL5@Slingsby.co.uk	Page 1 of 3	

8. Should both inspections at paragraphs 4, 5 and 6 be considered to be satisfactory, then proceed as follows:
- i) If intake duct assy is T67M-50-103 (Ref Figure. 2) no further action is required. Annotate logbook "SB169 complied with".
 - ii) If intake duct assy is T67M-50-101 (Ref Figure 1) then it is necessary to repeat inspection stages 4, 5 and 6 detailed within this Service Bulletin SB169 every 50 hrs flying hours, until Mod M760B air intake repair is invoked. When Mod M760B is incorporated annotate logbook "Mod M760B incorporated".

For assistance or replacement parts please contact SAL Customer Support Department.

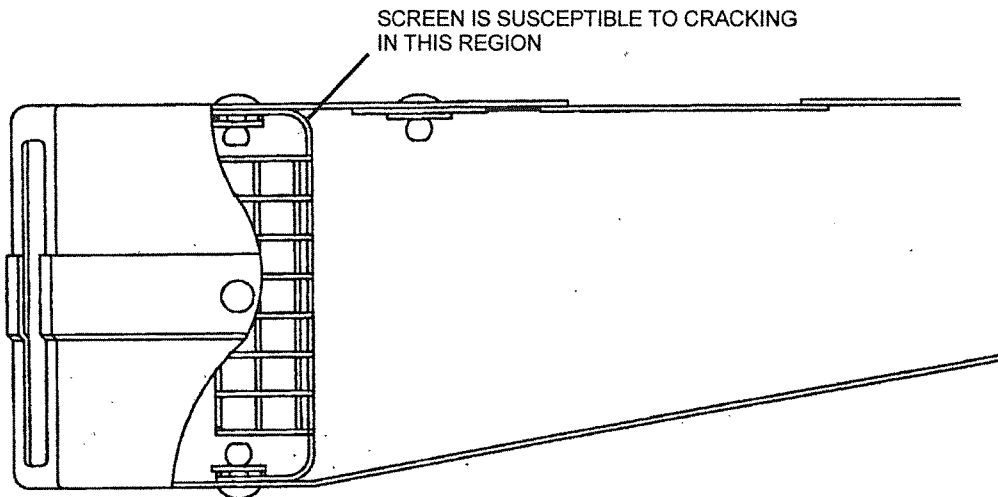

FIG. 1 AIR INTAKE DUCT T67M-50-101

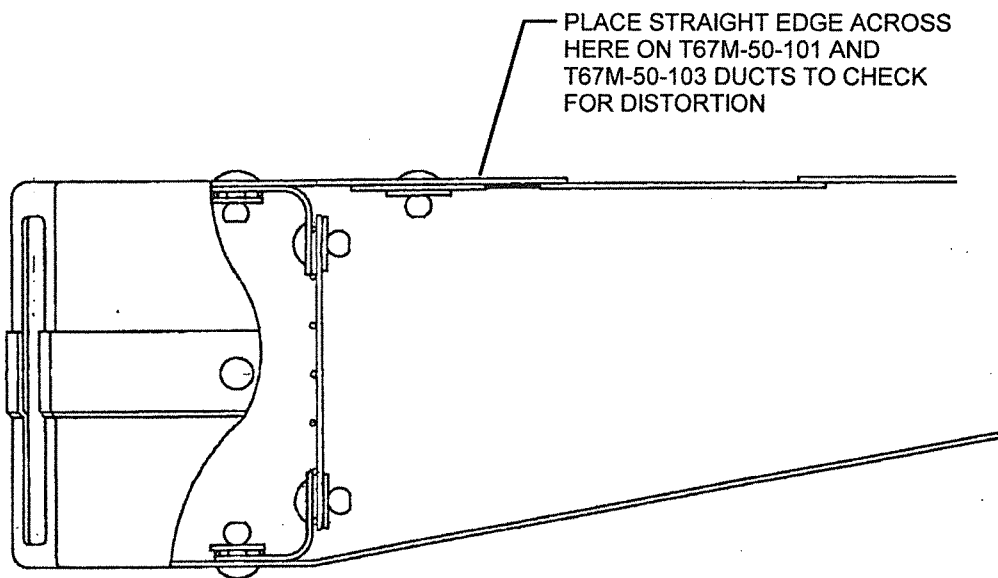

FIG. 2 AIR INTAKE DUCT T67M-50-103