

Service Bulletin

S.B. No: 157
Title: FIVE-YEAR FUEL TANK INSPECTION
Compliance: At next annual* and subsequently every 5 years.

*Not applicable if:

- a) Previous issues, i.e. 1, 2, 3, 4 have been invoked in previous 5 years;
- b) Aircraft are not yet 5 years old on receipt of this SB issue 5.

Applicability: T67B, T67C Series, T67M, T67M-MkII, T67M200 and T67M260 (Pre and Post Mod M945).

Issue 5. "Pre and Post Mod M945" added to Applicability; references to T67M260-T3A deleted; Figures 5 to 8 added showing fuel tank sealant areas for different fuel tanks; alternative sealant added for fuel filler panel sealing; component/material kits added for each fuel tank configuration for customer ordering purposes; components requiring return to SACL for re-work added; pressure test & ground run test added; Action section re-paragraphed accordingly; storage note added ref paragraph 23.

INTRODUCTION:

This Service Bulletin introduces an interior inspection of the integral fuselage tank or wing tanks, at five-year intervals.

- Note:
- 1 Not all items are applicable to fuselage tanked or wing tanked aircraft. Refer to relevant aircraft's IPC and Maintenance Manuals, where applicable.
 - 2 If Aircraft is stored or stood down for a period of time refer to Action Paragraph 23, page 4.

ACTION:

- 1 Perform the following inspections to the fuel tank/tanks after gaining access in accordance with the relevant aircraft's Maintenance Manual. Remove lower access panel, where applicable, IAW the relevant aircraft's Maintenance Manuals. For removal of the upper access panel, proceed as follows:
 - 1.1 This paragraph 1.1 is not applicable to the fuselage tank access panel. Carefully remove the Annular Vinyl Ring, using a warm air gun. Do not over heat wing skin, i.e. touch warm.
 - 1.2 Carefully remove paint, filler and sealant from around joint plus paint and filler from 12 off wing panel retaining screws or 22 off for the fuselage fuel tank panel.
 - 1.3 Remove screws.

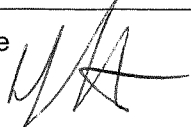
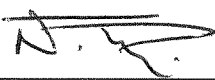
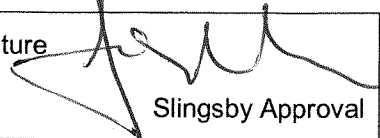
Signature  Compiled	Signature  Design CVE	Signature  Slingsby Approval
Print Name M.J. RITTEN	Print Name N. THORP.	Print Name D.W. GODDARD
Date 25-01-07.	Date 26-1-07.	Date 26-1-07
SLINGSBY ADVANCED COMPOSITES LIMITED Kirkbymoorside, York. YO62 6EZ Tel: 01751 432474 Fax No: 01751 431173 E-mail: SAL5@Slingsby.co.uk		Page 1 of 11 Issue 5

- 1.4 Carefully prise panel/s from wing skin or fuselage and sealant.
- 1.5 Clean panel/s and wing skin or fuselage recesses removing excess "brown" sealant and filler. Ensure, panel and wing or fuselage skin panel seating, have not been damaged. Do not damage the panel sealant. Ensure access panel bonding strip is exposed, Figure 2 refers.
- 2 Inspect internally the tank/s for general condition. Loose and peeling sealant. Flop tubes for hose clip tightness, correct location of flop tube spring, no distortion to spring, flexibility of Tygon tube and no damage to the flop tube. Avoid removing flop tubes.
- 3 Inspect for accumulation of sediment especially at drain valves and rib areas. Remove sediment.
- 4 Ensure correct operation of non-return valve/filter assembly, fuel drain and fuel level sender.
- 5 Ensure correct operation of flapper valves. Ensure seals on flapper valves have not deteriorated are not de-bonded, hard or sufficiently de-formed to allow incorrect seating. If any of these conditions are found, return assembly to SACL for rectification.
- 6 Check seals on Baffle plates – T67M fuselage tank, return baffle/s to SACL for re-work.
- 7 This paragraph 6 is not applicable to the following: fuselage-tanked aircraft, T67M-MkII Post Mod M516 aircraft (Works No. 2111, 2116 and subsequent), T67M200 (Works No. 2264 and subsequent) and T67M260 (Works no. 2072, 2234 and subsequent).
 - 7.1 Ensure wing drain valve is securely fastened into its retaining nut and that retaining nut is securely bonded to wing.
 - 7.2 Should nut not be bonded to wing, remove drain valve, clean retaining nut and skin surface. Bond nut to wing using adhesive 126-51-060. Ensure there is no adhesive blocking nut castellations or threads. Replace drain valve by using adhesive 126-51-067 (not required if nylon locking strip evident). Ensure adhesive does not contaminate drain mechanism. Torque valve to 50 lb in (5.65 Nm). Re-seal tank surface as required IAW Maintenance Manual. It is recommended that these drains are not removed from these types of aircraft for the de-fuelling process.
- 8 Ensure filters, vent lines and fuel lines are clean and un-obstructed.
- 9 Wing Tank Aircraft:
 - 9.1 Ensure vent line hose clips are correctly positioned Ref Figures 1a and 1b. If vent line cannot meet dimensions at both ends, then replace vent line with new tube (SACL Stores Code 126-36-054). Ensure the requirements of Service Bulletin SB161 Fuel Tank Vent Pipe Check are met.
- 10 Ensure all rib holes are clean and unobstructed, including holes in collector panels.
- 11 If applicable, ensure correct operation of fuel low-level sensor/warning light.
- 12 Check for fungicidal attack throughout fuel tank assembly.
- 13 Check filler cap adjustment IAW relevant aircraft's Maintenance Manual.
- 14 Rectify any faults found.
- 15 Prior to re-assembly, ensure tank is free from contamination and foreign objects.
- 16 Reassemble fuel tank internal components and lower access panels (wing tanked aircraft). Ensure relevant items are replaced and sealed IAW the relevant aircraft's Maintenance Manual. On wing tanked aircraft ENSURE fuel pick-up is correctly positioned, i.e. on top of the baffle, refer to relevant aircrafts Maintenance Manual.

- 17 Perform Fuel Tank pressure test IAW relevant aircrafts Maintenance Manual.
- 18 Should resealing be required ensure sealant does not cover Low Fuel Level Sensor - where fitted -, Fuel Senders, Drain Valve/s & their outlets, Fuel Outlets, Flop Tube assemblies where fitted, Vent orifices, or Flapper Valves - where fitted. Mask as required; ensure masking is removed when sealant cured.
- 19 Check fuselage sender/gauge calibration as follows, (see paragraph 20.7 for wing fuel sender):
- 19.1 Ensure fuselage datums are set horizontal refer to datum leveling in Maintenance Manual, paragraph 2.1.
- 19.2 If necessary ensure that there is fuel in the pipelines etc. to the level of tank base.
- 19.3 Pour in 4.5 litres of fuel T67B and T67C aircraft or 9 litres for T67M aircraft. Check gauge reading is zero (0).
- 19.4 If reading is not zero then carefully bend sender arm until reading is zero.
- 19.5 Add half a litre of fuel, check for immediate change in fuel gauge reading.
- 19.6 Fill tank in 4 gallon* steps. Gauge reading to equal quantity contents.
- 19.7 If in doubt at any point contact SACL.
- * Ensure correct units as per marked gauge, i.e. Imperial gallons or US gallons.
- 20 Replace the fuel filler access panel/s as follows:
- 20.1 Check integrity of bonding strap, on the wing or fuselage and access panel.
- 20.2 Check that the sealant around the anchor nuts is in good order repair by painting with sealant 126-51-038 use 30mm margin around any damage. Ensure end of bonding strip is sealed, refer Figure 4.
- 20.3 Check that panel sealant is in good order, if required paint with sealant 126-51-030.
- 20.4 Refit access panel/s using sealant 126-51-038 or gasket sealant 126-51-031, applied IAW Figure 3. Ensure bonding strips are aligned. Use screws 126-21-116, fasten screw at bonding position first, and then diametrically opposite followed by remainder. Torque to 20-25 lb ins before sealant has cured as per previous sequence. Ensure continuous bead of sealant has formed around circumference of panel and that panel is flush or below surface. If below surface, ensure no more than 2mm. It is acceptable for sealant to ooze out at screw positions.
- 20.5 Using gloved finger remove bead of sealant (before cured), leaving a curved-bottomed groove. Allow sealant to cure, Figure 4 refers.
- 20.6 After sealant has cured, replace filler cap and check tanks for pressure and perform bonding tests, (0.02 ohms or less), IAW relevant aircraft's Maintenance Manual. Rectify as required.
- 20.7 Check wing fuel sender/gauge calibration as follows, (see paragraph 19 for fuselage tank):
- 20.7.1 Ensure fuselage datums are set horizontal; refer to datum leveling in Maintenance Manuals, paragraph 2.1.
- 20.7.2 Pour two litres of fuel into each tank and ensure that the contents gauges read zero (0). If zero cannot be achieved contact SACL.
- 20.7.3 Add fuel in one gallon* increments up to 15** gallons in each wing tank and read off and record the corresponding gauge readings. Tabulate reading and ensure they are within the specified limits as indicated in Table 1.

If in doubt contact SACL.

* Ensure correct units per marked gauge, i.e. Imperial gallons or US gallons

** Note the fuel sender arm float reaches the top of the fuel tank at around 15 gallons, therefore the calibration exercise need not proceed beyond 15 gallons actual fuel contents.

- 20.8 Prior to flight, perform ground run to purge system. When satisfactory fuel flow is achieved, carry out fuel flow check IAW relevant aircraft Maintenance Manual.
- 20.9 Remove beads of sealant from screw heads and, if necessary, fill screw heads and recessed panel flush, with filler 128-52-052. Note remove paint where required before filling.
- 20.10 At this point for fuselage tanked aircraft, mask area, if required, for painting. Mask groove. Paint IAW T67 GRP Repair Manual, paragraph 2.9.4 refers. Continue as paragraphs 20.14 and 21 and subsequent
- 20.11 Once dry remove masking and using lining tape, line edge of groove. Ensure tape level. Refer Figure 4.
- 20.12 Fill groove to the level of the tape using acrylic sealant 126-51-039. Allow to cure.
- 20.13 Remove tape and if necessary, remove excess sealant until flush, using 1500 grade wet and dry.
- 20.14 Perform Fuel Tank pressure test IAW relevant aircrafts Maintenance Manual. Should resealing be required ensure sealant does not cover Low Fuel Level Sensor - where fitted -, Fuel Senders, Drain Valve/s or Flapper Valves.
- 20.15 Paint IAW T67 GRP Repair Manual, paragraph 2.9.4 refers.
- 20.16 Apply new annular rings T67F-00-301, wing tanked aircraft only.
- 21 Annotate Logbook "SB 157 complied with".
- 22 Repeat paragraphs 1 to 20 every 5 years.
- 23 For aircraft stood down or stored proceed as follows:
- 23.1 If aircraft is to be stood down over a long period, then ensure fuel in tank covers fuel sender base. Quantity required for fuselage tanked aircraft is approximately 10 Imp Gal or for wing tank maximum is 10.2 Imp Gal, Minimum 5.6 Imp Gal.
- 23.2 If aircraft has been in store for more than 12 months without fuel covering fuel sender base, then tank is to be pressure tested IAW the relevant aircrafts Maintenance Manual. If the sender leaks then replace sender.

Five-year inspection material/component kits are available as follows for the following aircraft:

T67G-98-1013 applicable to T67M260 Post Mod M945, works numbers 2266 to 2284.

T67G-98-1014 applicable to: T67M-MkII works numbers 2116 to 2122, T67M200 works number 2264 & 2265 and T67M260 Pre Mod M945 works numbers 2072, 2234 to 2260, 2262 & 2263.

T67F-98-1000 applicable to: T67C wing tank (Post Mod M156), T67M-MkII & T67M200 works numbers 2017, 2018, 2021, 2027, 2031 to 2033, 2038 to 2042, 2044 to 2051, 2054 to 2057, 2059 to 2061, 2067, 2069, 2073 to 2081, 2083 to 2108 & 2111 to 2115.

T67B-98-1000 applicable to; T67B & T67C (Pre Mod M156) fuselage tanked works numbers 2008, 2011, 2013 to 2016, 2020, 2023, 2026, 2028 & 2035 to 2037.

T67M-98-1000 applicable to T67M fuselage tanked works numbers 1999, 2000, 2002, 2003, 2004, 2009 & 2010.

Issue 5 amendments will be incorporated into Maintenance Manuals at next amendment.

For any assistance required, please contact SACL Customer Service Department.

Fuel Tank Contents			Permitted Readings	
Actual	Indicated		Max (gals)	Min (gals)
	Port (gals)	Stbd (gals)		
2 litres (gals)	0	0	0	0
1			1.0	0.5
2			2.0	1.0
3			3.0	1.5
4			4.0	2.5
5			5.0	3.0
6			6.0	4.0
7			7.0	5.0
8			8.0	6.0
9			9.0	7.0
10			10.0	8.0
11			11.0	9.0
12			12.0	10.0
13			14.0	11.0
14			15.0	12.0
15			15.0	13.0

TABLE 1 WING TANK FUEL CONTENTS TO GAUGE READINGS

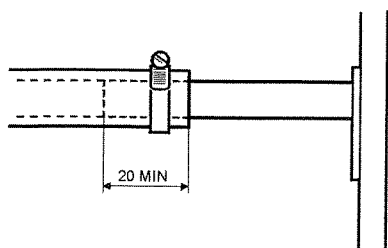

FIGURE 1a PRE MOD M500/M554

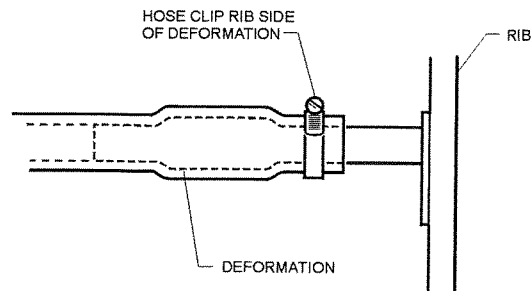
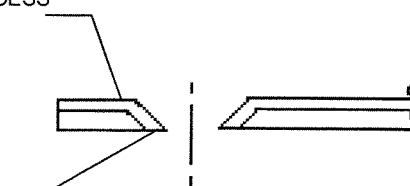

FIGURE 1b POST MOD M500/M554

METAL FILLER SURROUND ON ACCESS
PANEL AT BONDING POINT

ENSURE METAL EXPOSED



PART SECTION THRU SCREW HOLE IN ACCESS PANEL

FIGURE 2

SEALANT 126-51-038 or 126-51-031
TO BE APPLIED AS SHOWN ALL
AROUND FASTENER HOLES

FASTENER
HOLES

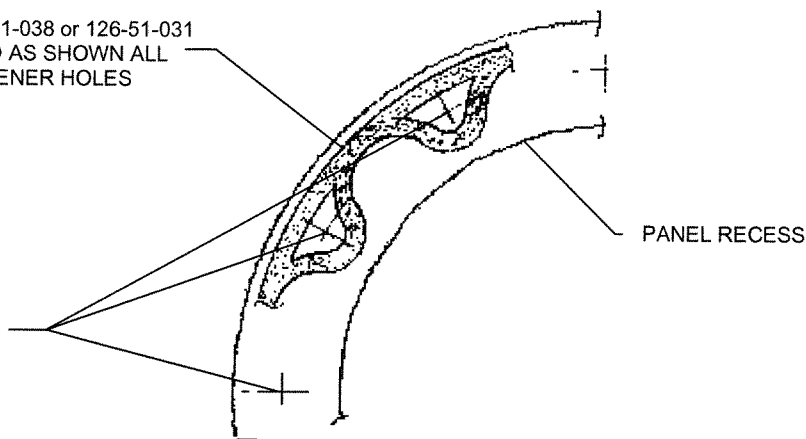

FIGURE 3

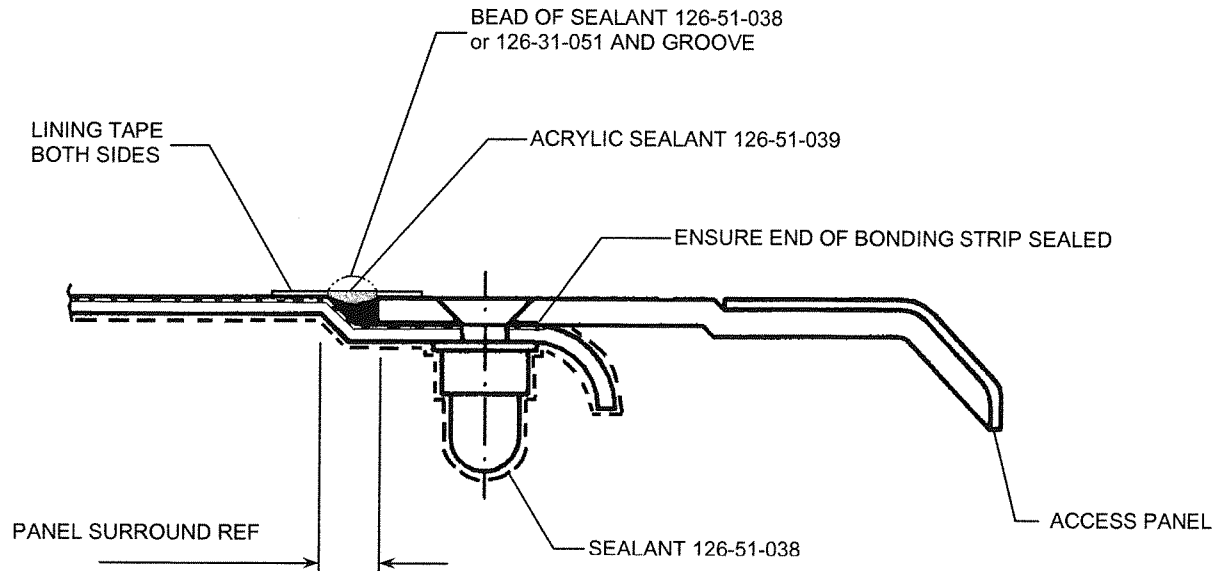

FIGURE 4

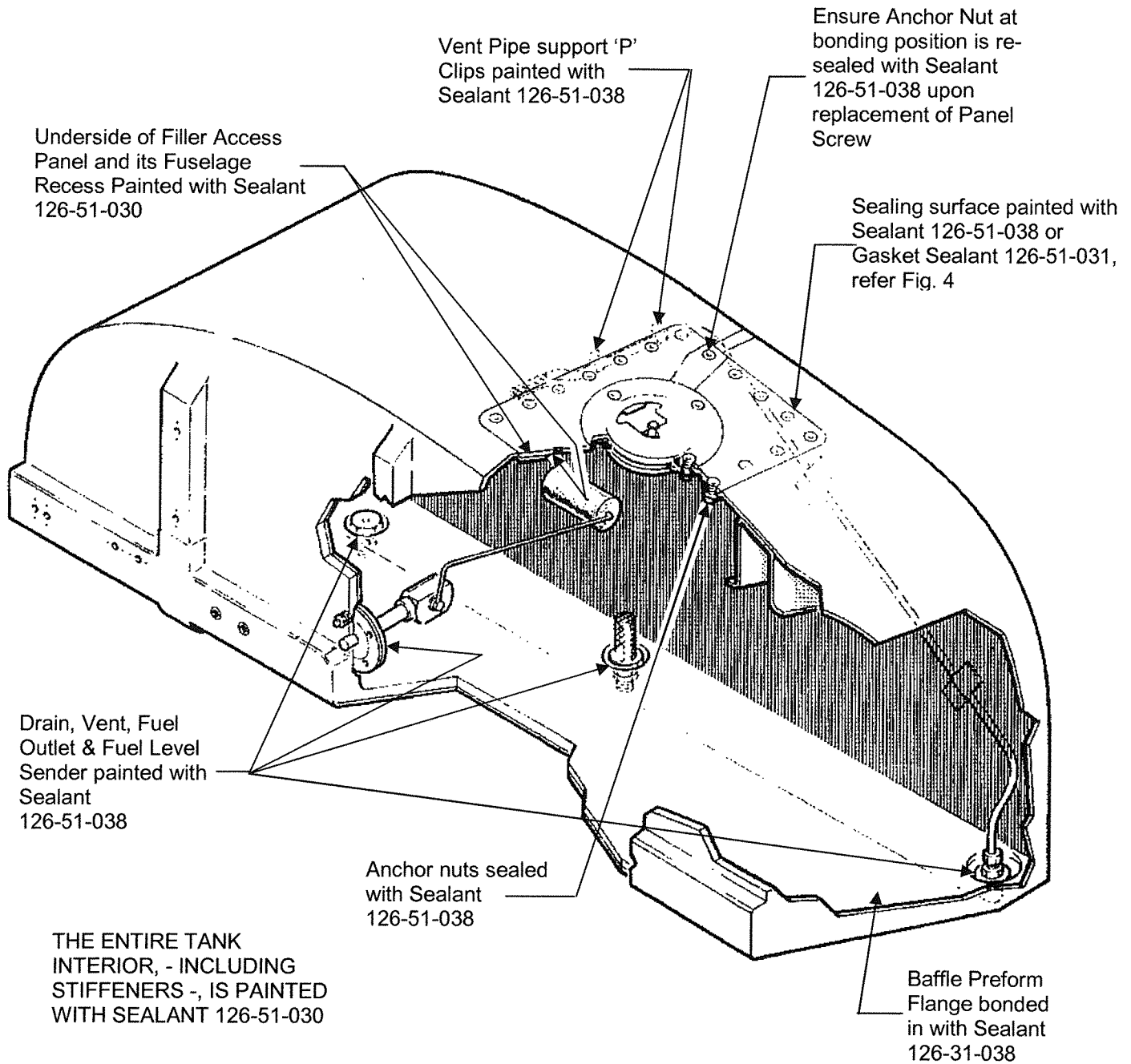

FIGURE 5
FUSELAGE TANK
(T67B & T67C PRE MOD M156)
(Sealant areas as per New Build)

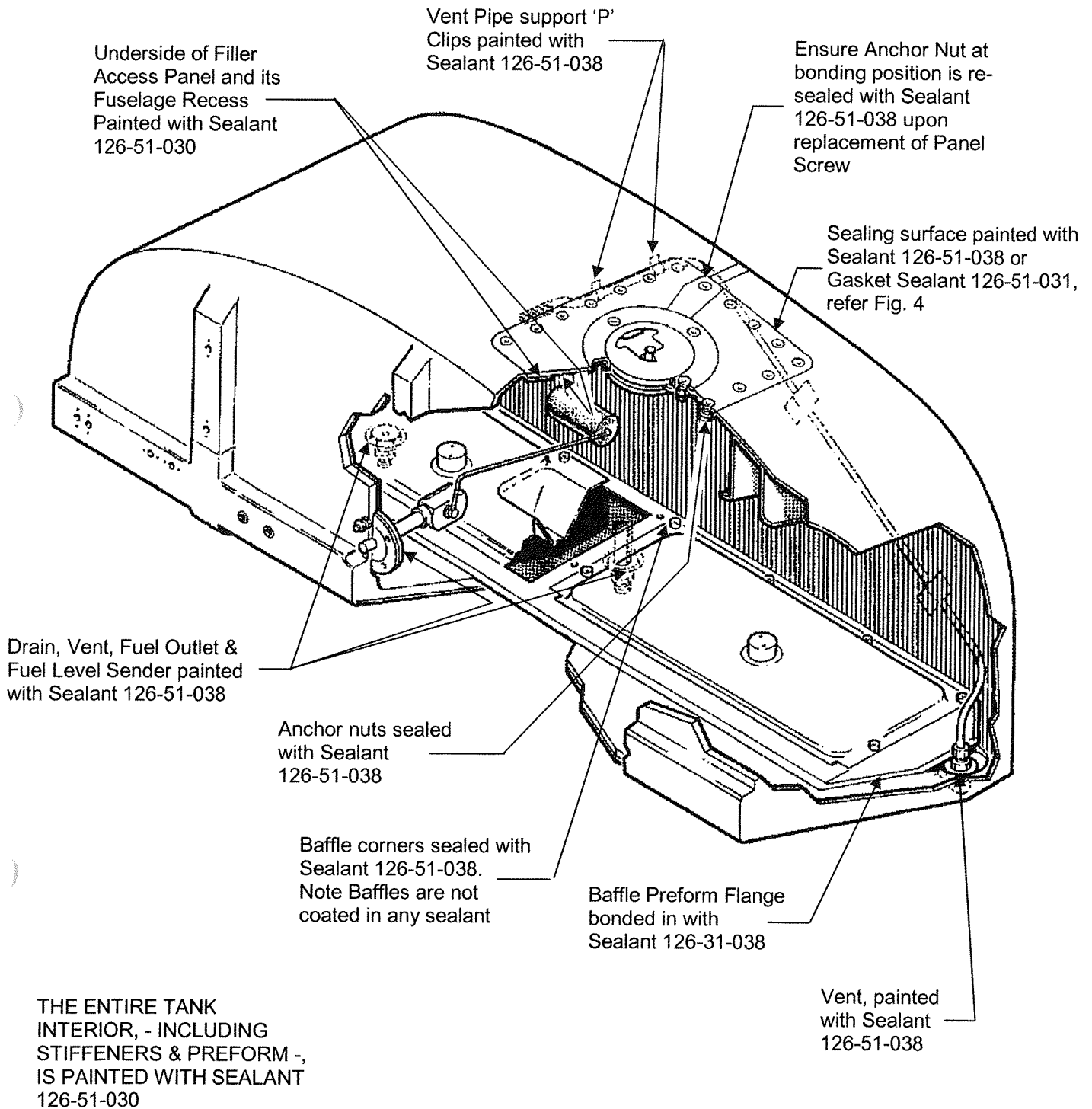

FIGURE 6
FUSELAGE TANK
(T67M)
(Sealant areas as per New Build)

