

**Service Bulletin**

S.B. No: 188

**Title:** INSPECTION FOR RUDDER PEDAL CLEARANCES BETWEEN RUDDER PEDALS AND THE AIRCRAFT STRUCTURE AND COMPONENTS

**Compliance:** Within 50 flying hours from receipt of this Service Bulletin and every subsequent Annual.

**Applicability:** T67B, T67C series, T67M (excluding works no. 1999), T67M-MkII and T67M200 (excluding works no. 2264 & 2265).

**This Service Bulletin is the subject of an Airworthiness Directive.**

This issue 2 has been raised to incorporate feedback from customers. All added/changed paragraphs and drawings are indicated by a vertical bar in the left hand margin.

**INTRODUCTION:**

This Service Bulletin is issued to reinforce the importance of ensuring correct clearances and maintenance of the rudder operating mechanism, mountings and stops to ensure the required clearances for safe operation.

The issuing of this Service Bulletin follows an incident, which occurred during spinning. During spin recovery a rudder pedal fouled a component. On inspection it was observed that the floor was damaged allowing the rudder bar support bracket to distort and the bar and its pedal to float to the left greater than the limit allowable for safe operation.

This Service Bulletin pulls together other Service Bulletins, which have been raised in the past to address clearance issues. The information contained within this Service Bulletin supersedes the Service Bulletins listed below and Maintenance Manual instruction regarding clearances where applicable.

SB 015 Rudder Pedal to sidewall and Rudder Cable Clearances.

SB 044 Check on Clearance Between Forward U/C Leg and Engine Mounting Frame.

SB 049 Rudder Mechanism to Fuel Pipe Clearance Check.

SB 051 Inspection of Rudder Cable to Link Plate Socket Head Cap Screw.

SB 071 Inspection of Rudder Pedal Lay shaft Mounting Brackets.

SB 083 Inspection for Foul Between No.2 Rudder Pedal Pad Pivot and Nose wheel Steering Rod Arm.

SB 168 Inspection of Cockpit Floor Beneath Port Rudder Bar Support Bracket.

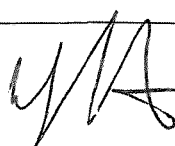
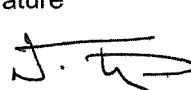
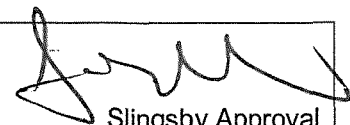
Signature  Compiled	Signature  Design CVE	Signature  Slingsby Approval
Print Name M.J. RUTTER.	Print Name N. THORP.	Print Name D.W. GODDARD
Date 10-05-07.	Date 10-5-07.	Date 10-5-07
SLINGSBY ADVANCED COMPOSITES LIMITED Kirkbymoorside, York. YO62 6EZ Tel: 01751 432474 Fax No: 01751 433016 E-mail: mike.rutter@slingsby.co.uk		Page 1 of 11 Issue 2

**ACTION:**

**Prior to starting inspections it is recommended that this Service Bulletin is read in its entirety and understood. If in doubt, contact Slingsby Advanced Composites Ltd, (SACL).**

1. The rudder pedal operating mechanism is to be checked for full and free movement in all aspects of normal operation and abnormal operation, e.g. application of toe brakes during extreme pedal deflections during spin recovery. The checks are to take into account all rudder pedal adjustment positions. It must be noted that during the clearance checks the pedals do not necessarily have a direct fore and aft load applied, there will be side loads on the pedal pads deflecting the pedal pad laterally or pivoting it about its slider.
  2. Check forward, aft and lateral play in pedal pads and their sliders, ensure play is no greater than 5mm when pedals locked in any of the adjustment positions. If greater than 5mm then assembly requires refurbishment. Consult SACL if required.
  3. Check rudder pedal bar end float is no greater than 0.8mm. Acceptable end float is 0.0mm to 0.8mm. If end float is greater than 0.8mm then rectify end float IAW paragraph 8. Refer Figure 1.
  4. Check that the Rudder Pedal bar port outboard support bracket, ref. Figure 1 and 3, is square to the floor and not "lozenged" and there is no deformation to its base. Check floor panel under area of bracket, inspect for cracking which could allow the bracket to lean. If necessary remove floor panel and check for signs of cracking in the floor around the anchor nuts on Pre Mod M919 aircraft or the anchor nut mounting plate Post Mod M919 aircraft, refer Figure 2. Any GRP damage will be shown as a white shadow on the GRP, with cracking felt as a rough edge. A light shining up through the floor will show a shadow.
  5. If floor under port outboard support bracket is found to be cracked or broken then repair IAW DOI T67C-149 incorporating Mod M919. If Mod M919 has been previously incorporated and floor is damaged inform SACL.
  6. Should Rudder bar support bracket be damaged replace with new item. Ensure bracket is secured with a torque of 58lbf in (6.5Nm). Spring washers may be fitted; Mod M720 "Introduction of Spring Washers to Rudder Pedal Lay-shaft Mounting Bracket Screws" refers. See Figure 1. Ensure when refitting brackets that the saddle washer, T67M-45-537, is re-fitted and is assembled with its corner radius into the brackets radius, refer Figure 1. Ensure that the taller mounting brackets are supporting Rudder Pedal Bar T67M-45-257, i.e. Port Rudder Bar, refer Figures 1 and 3.
  7. Check the remaining rudder bar support brackets, ref. Figure 3, are square to floor and are not "lozenged" and there is no deformation to their bases, reference Figure 1. If any bracket is found to be suspect replace with new item. Check floor under any damaged support bracket by removing panel. Ensure washers and brackets are correctly assembled refer paragraph 6 above. Inform SACL of any damaged bracket or additional floor damage. Assemble item as per paragraph 6 and ensure end float is as stated in paragraph 8. Ensure bonding leads are correctly fitted, carry out bonding check refer relevant aircraft's Maintenance Manual.
- Note: An identifiable cause for the distortion of the rudder support brackets is ground handling the aircraft with a vehicle, whereby the towing arm has been outside of the limitation markings on the cowling when the aircraft is turned. However if there is damage to the support brackets and the aircraft has knowingly never been towed by a vehicle then inform SACL. If the cowling has been repainted and/or limitation markings are missing then contact SACL for correct limitation marking positioning.
8. Referring to Figure 1 ensure at each rudder bar pivot position that there is one spacer T67M-45-507 OR one off washer 126-23-748 and up to a maximum of two off washers 126-23-749, i.e. 3 washers maximum.
- If end float greater than 0.8mm, then 1 off packing washer may be added at each pivot position as required, i.e. 126-23-105 washer or 126-23-748 washer or 126-23-749 washer.

If packing washers are required on the right hand rudder bar (T67M-45-259), then the packing washer, (or the thicker washer if a thick and thin washer are required) should be placed at the outboard pivot. When end float of 0.8mm maximum achieved ensure that the brake cylinders are not subject to undue side load. If in doubt contact SACL

Note1: it is imperative that the combination of packing washers is adhered to as any more than the stated amount may allow the rudder bar mounting brackets pivots to become out of safety.

Note 2: 126-23-105 or 126-23-748 are 1.6 mm thick and 126-23-749 is 0.81mm thick.

Note 3: Ensure after packing, that the bars are not binding and have full and free movement.

9. Ensure the rudder pedal carriages have full and free movement. If binding is suspected then check the 'U' bracket internal dimension. This should measure 35.0mm to 35.5mm, the bracket should also be parallel and square to the rudder bar axis, Figure 7 View on 'A' refers. Check that the pivot bush protrudes from its boss by 0.5mm. If the bracket internal dimension is greater or less, or if out of alignment then the bracket should be checked for cracking, refer Figure 7. If cracking is found then return rudder bar to SACL for rework. Finally check length of carriage pivot bolts, reference Figure 3, if binding is noted then replace bolts with bolt part number T67B-08-537 this introduces a bolt 15 mm long, measured from under head, and invokes Mod M808 "Introduction of Shortened Pivot Bolt to Rudder Pedal Slider Assembly Mounting". Also refer to SB130 Inspection of Rudder Pedals for Adjustment Restriction".

Note 1: Use NDT methods, (dye penetrant) for detecting structural defects e.g. cracks, ensure paint is removed from the suspect area before carrying out test. If defect found replace item or return to SACL for rework. If no defects are found, remove all NDT materials and re-apply finish.

Note 2: Note rudder stop plates, positions indicated on Figure 3, are permitted with deformation assuming full rudder movement and clearances have been achieved and there is no cracking in the welds supporting the stop plates, if in doubt return rudder bar to SACL for rework.

10. Prior to checking rudder movements, remove and inspect that the rudder bar stop bolts are 40mm long under their heads and that the stop mountings in the floor panels pedestal are structurally sound. If stop is not 40mm then fit longer item T67B-45-613, Post Mod M458. Check threaded portion of stop for straightness change if bent. If, it is noted that the stops are screwed fully in, then check rudder cable length, reference paragraph 14. Check play in links, i.e. for elongated holes. If holes are elongated replace links with new item/s. Replace rudder cable when turnbuckles are at the end of their adjustment.
11. Check the rudder pedal movement ensuring that the rudder set-up procedure in the relevant aircraft Maintenance Manual is adhered to. It is recommended that the rudder movement board T67B-88-027 is used.
12. Ensure Trim Panel Modification M992 "Introduction of Fasteners to Front of Frame 2 to 3 Trim Panel for Added Security" has been incorporated, UK CAA AD 005-02-2003 refers.
13. Upon completion of rudder movement set-up ref. Paragraph 11 above. Ensure minimum clearances of trim panel to pedal side plates and rudder cable to pedal side plates are met Figure 3 refers. If necessary to obtain the required clearances, Mod M232 "Introduction of Rudder Pedal Packing for Increased Clearance of Surrounding Components" may be required to be invoked. Refer paragraph 7 for packing washers on rudder bar.
14. Ensure fuel pipe to rudder pedal slider clearance of is met, refer relevant aircrafts Maintenance Manual Paragraph, 5.6.5.1, where relevant the minimum acceptable clearance is now to be 5mm. If clearance cannot be achieved then; i) remove Rudder Cable and check length, length should be 4862  $\pm$  2 mm, Figure 6 refers; ii) additionally check condition of rudder pedal assembly, refer paragraph 2.
15. Ensure head orientation of rudder cable link bolt head is outboard, Figure 3 refers, this is a Low Pan Head bolt T67M-45-570 on Post Mod M471 "Introduction of Pan Headed Bolt on Rudder Cable Turnbuckles", aircraft.

16. Ensure Pedal no 2 Pedal pad pivot bolt head height is less than 5mm and orientated as shown in Figure 4. A minimum of 1mm clearance is required, if not fit part no 126-21-210 or T67B-08-981, this invokes Mod M671 "Introduction of Low Head Rudder Pedal Pad Pivot Bolts – Pedal No. 2". If clearance is not still achieved check distance of steering arm from bar end, Figure 3 specifies. If the distance is incorrect, then return rudder bar to SACL for re-worked/new item. Alternatively if clearance of 1mm is still not achievable remove up to a maximum of 1.5mm from the steering arm screw this invokes Modification action M1029, Figure 4 refers, and paint modified screw head red.
17. Ensure the requirements of, SB 99 "Inspection and Rectification of Rudder Pedal Sliders", has been met. If all of the actions as quoted in SB99 have not been previously incorporated then monitor, at every 150 hours, for loose rivets until SB99 requirements are incorporated in their entirety.
18. Ensure Mandatory Mod M576 has been invoked; AD 013-05-94 refers. Pedal side plate should be as Figure 8.
19. Check structural integrity of pedal pad assembly especially around adjuster pushrod hole pedal plate, Figure 8 View on Arrow 'B' refers, if plate is cracked or damaged the pedal pad is to be repaired. Ensure riveting is secure, if rivets are loose then they have to be rectified. Contact SACL for new pedal pad assembly, materials and any applicable repair scheme.
20. Ensure rudder pedal carriage socket head caps screws are wire locked and bonded in with adhesive 126-51-024, use minimum amount, Mod M162 "Wire Locking of Rudder Pedals – Upper Pivots", refers. See Figure 3.
21. Ensure on aircraft fitted with the Fairey Hydraulic undercarriage, (Post Mod M468 or Mod M791), that there is a minimum clearance of 2.5mm with steering linkage to engine mounting frame, see Figure 5. Ensure there is no damage to engine mounting frame if clearance is less than 2.5mm. If engine mounting frame is damaged then aircraft must not be flown until damage is rectified, consult SACL. Also if clearance is less than 2.5mm embody Mod M575 "Introduction of Offset Steering Arm Pin – Ref Fairey Hydraulics Nose U/C", if Mod M575 is fitted and clearance is less than 2.5mm inform SACL.
22. Ensure on the Annual inspection or during any maintenance in the area of the rudder pedal mechanism - e.g. trim panels removed - or upon removal of any of the rudder pedal operating mechanism, that the clearances in the areas noted in paragraph 2 to 21 above are met.
  - 22.1 It must be noted that during the clearance checks that the pedals do not necessarily have a direct fore and aft load applied, there will be side loads on the pedal pads deflecting the pedal pad laterally or pivoting the pedal about its slider.
  - 22.2 Ensure that the rudder pedal operating mechanism is checked for full and free movement in all aspects of normal operation and abnormal operation, e.g. application of toe brakes during extreme pedal deflections during spin recovery.
  - 22.3 Ensure any wire locking employed, e.g. on cable turn buckles, will not foul or snag either adjacent parts or pilots clothing.
  - 22.4 Ensure fastenings have the correct torque applied IAW with the relevant aircrafts Maintenance Manuals as applicable.
  - 22.5 Always check the structural integrity of the rudder operating mechanism, inform SACL of any abnormality or if clearances cannot be met. Send components to SACL for replacement or repair, there may be a charge for this service.
  - 22.6 Ensure all clearance checks are undertaken at all rudder pedal adjustment positions.
  - 22.7 Ensure that instrument panel forward console sideplate ty-rap is replaced; IPC Chap 30, Figure 2 refers. Console width to be no greater than 132mm after ty-rap applied.

- 22.8 On the completion of this Service Bulletin's inspection and rectification procedure, ensure that each rudder pedal mechanism clearance is still as stated and has not been affected by any subsequent adjustment/s or rectification/s.
- 22.9 Ensure all cabling and ducting is secure and will be clear from the rudder pedal mechanism in all its positions, consider movement of cables during under when aircraft pulls 'g' loads. Any loose cable/ducting to be secured.
- 22.9 Clearances, quoted in this Service Bulletin over-ride any clearances, quoted in the relevant aircraft Maintenance Manual.
23. If correct rudder movement and rudder operating mechanism clearances are met, annotate Logbook with "SB 188 incorporated", at each inspection.
24. At each subsequent Annual inspect IAW this Service Bulletin in its entirety until such time that the relevant aircrafts Maintenance Manual and Schedule are amended. Additionally, Maintenance Organisations are to ensure that the inspections contained in this Service Bulletin are added to their specific Maintenance Schedules where applicable.

For further information, existing repair schemes or Mod/Service Bulletins please contact SAAC Customer Support. Please note these services may be subject to a charge, unless an individual or company has a Support Agreement or Subscription Service in place. For parts and non-existing repairs a charge may be made.

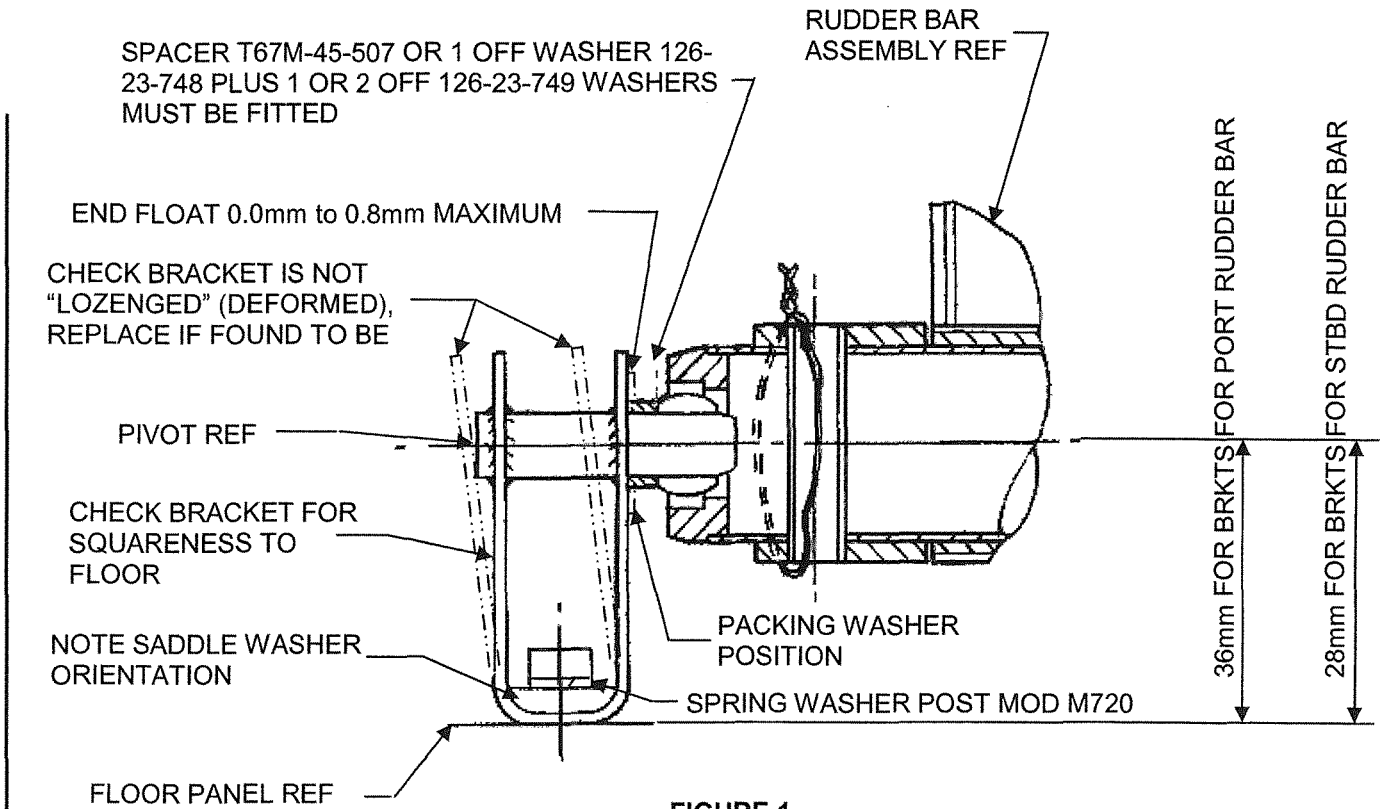

RUDDER BAR END FLOAT AND ITS SUPPORT BRACKET

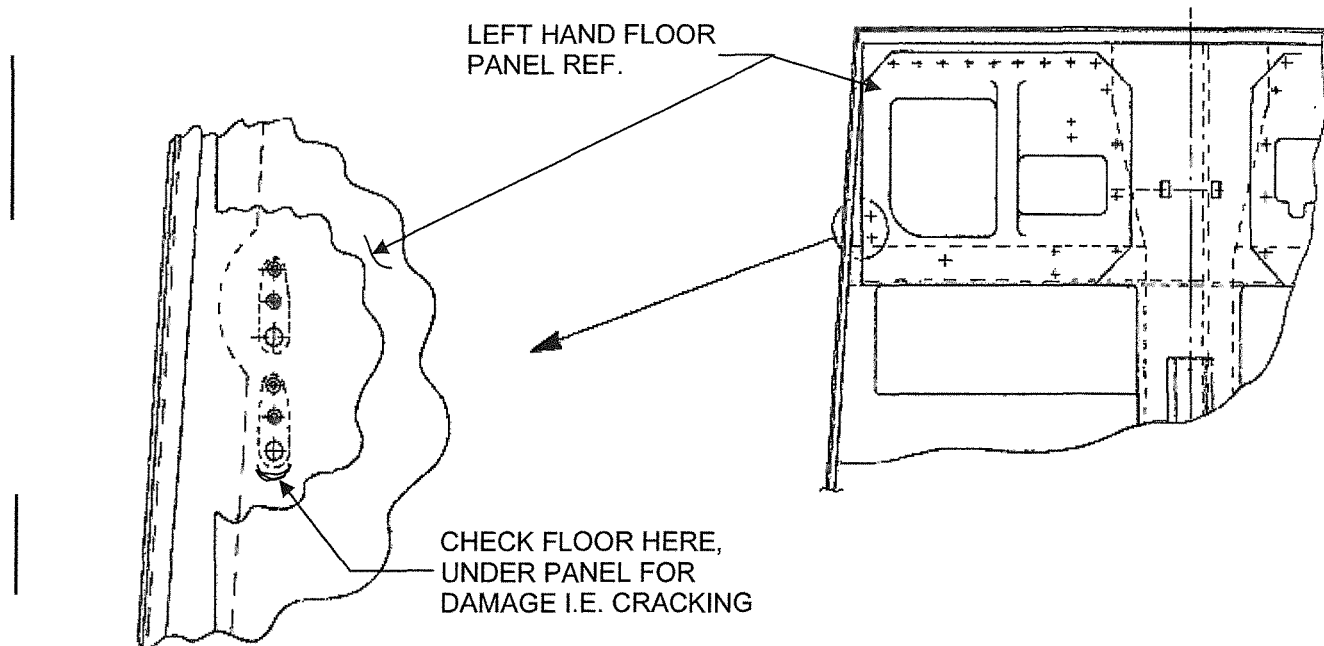

AREA OF FLOOR REQUIRING INSPECTION (PRE MOD M919 DRAWN)

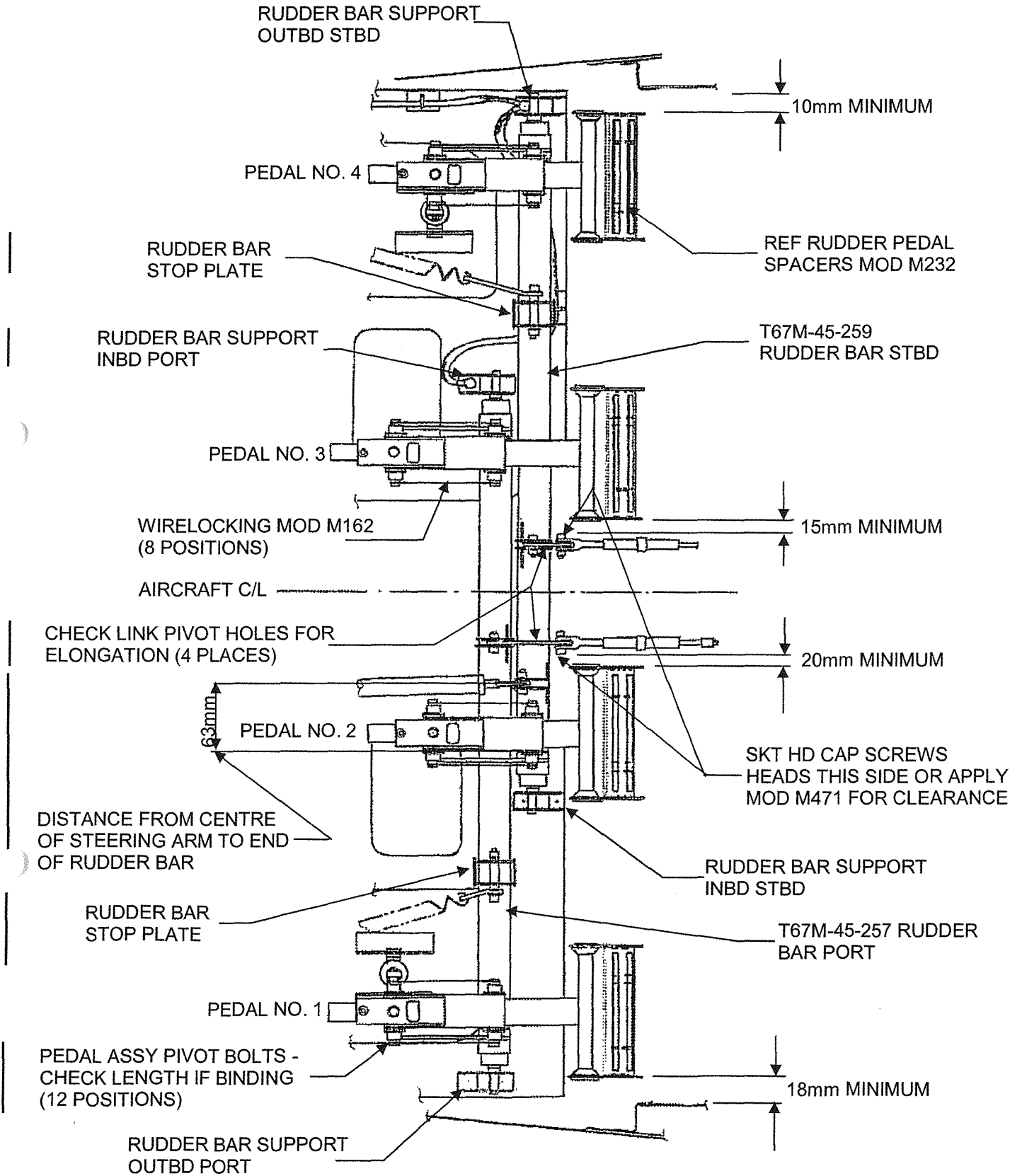

FIGURE 3

### RUDDER PEDAL CLEARANCES TO SIDE PANEL AND RUDDER CABLES

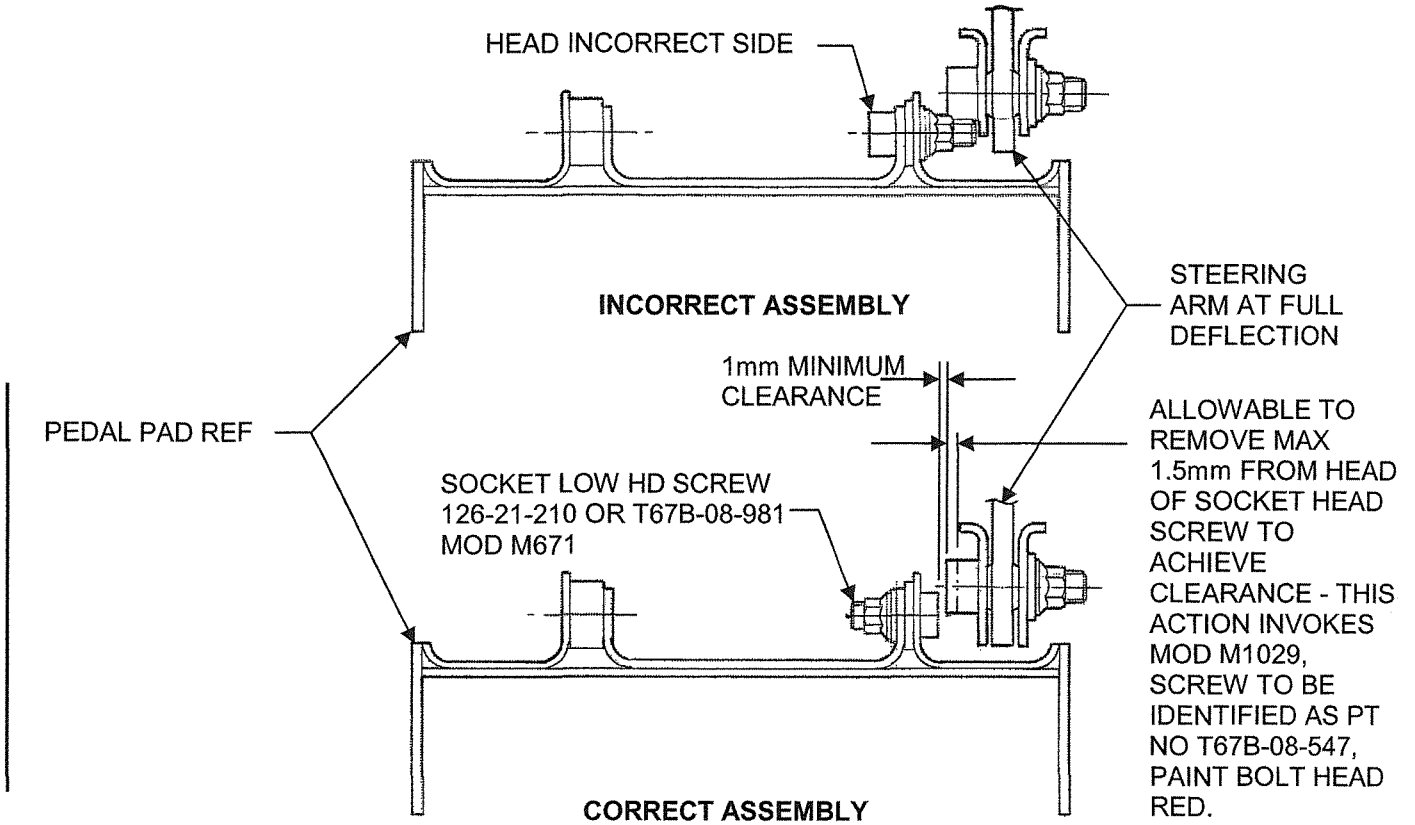

FIGURE 4

### PEDAL NO. 2 TO STEERING ARM INTERFACE

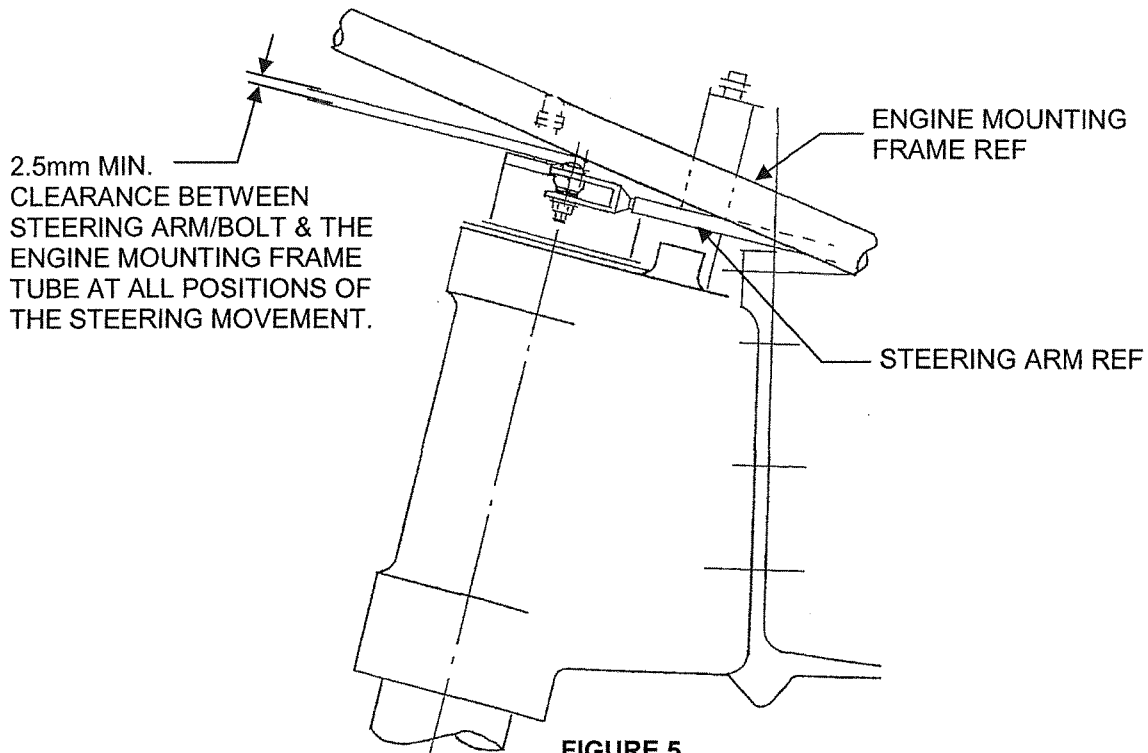
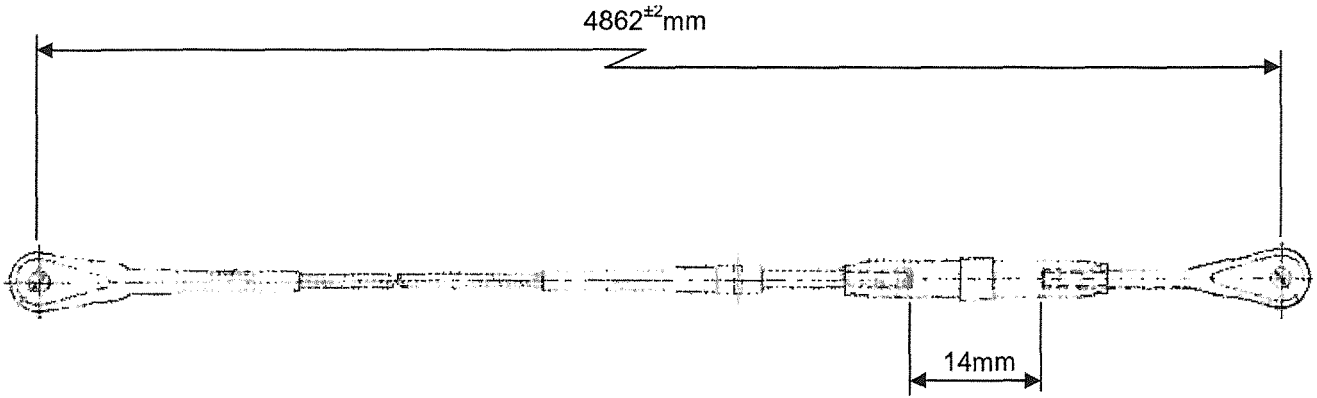

FIGURE 5

### STEERING ARM ENGINE MOUNTING FRAME CLEARANCE





**FIGURE 6**

**RUDDER CABLE T67B-45-219  
(ORIGINAL MANUFACTURED DIMENSIONS QUOTED)**

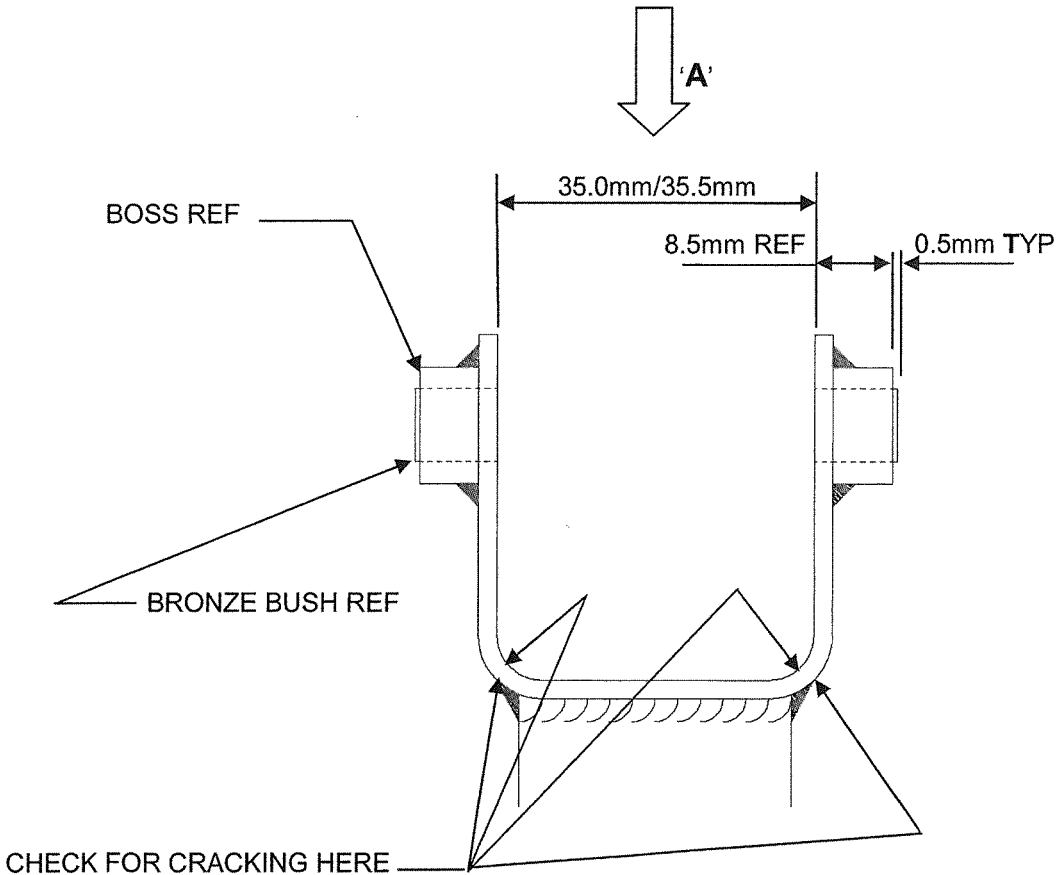
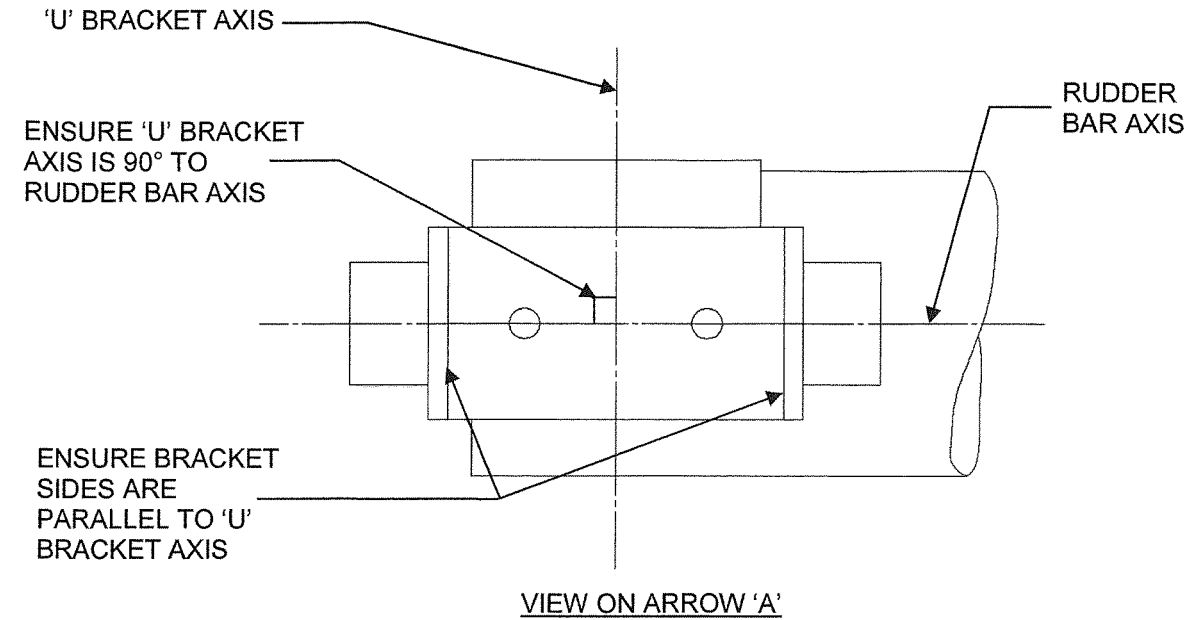

FIGURE 7

'U' BRACKET ON RUDDER BARS  
(4 POSITIONS)

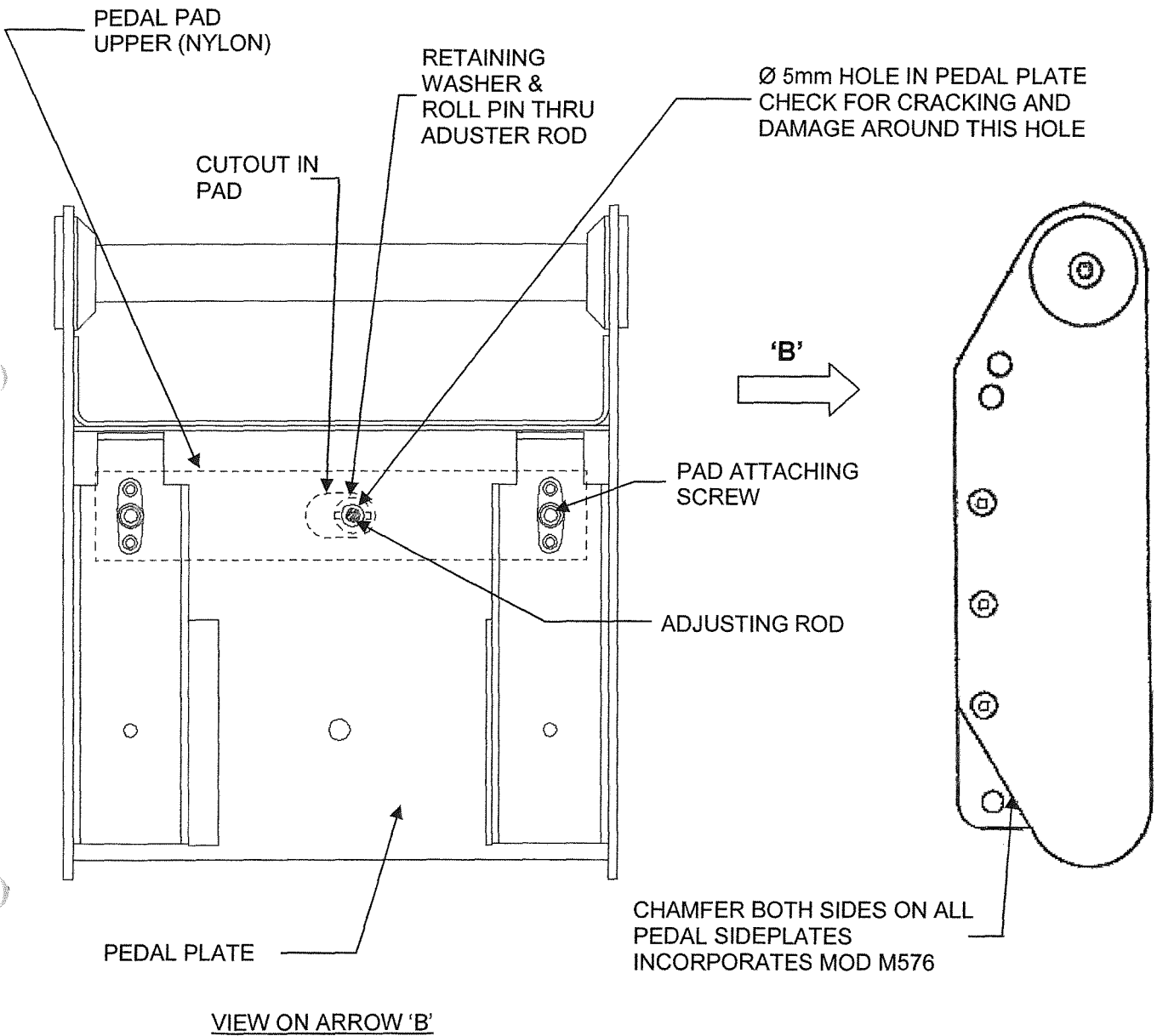

FIGURE 8

MOD M576 PEDAL SIDEPLATES WITH CHAMFER